

Hien[®]

DC INVERTER AIR TO WATER HEAT PUMP

MONOBLOC

Heating+Cooling+DHW



CLOVERLIFE SERIES





ABOUT HIEN

Founded in 1992, Hien firstly started as an electronic component manufacturer. With a registered capital of 300 million RMB, Hien entered the air source industry in 2000. It is a leading enterprise of air source heat pumps in the area of product R & D, production, sales, and after-sales service. Hien owns one of the largest production bases of heat pumps in China, as well as the CANS certified state-level comprehensive laboratory.

PRODUCTION LINE

With a total of 60,000 m² of construction area and over 1,000 processing equipments, the main factory comprises 6 assembly lines, while the branch factory consists of 3 production workshops. Main products include air source heat pumps for residential, commercial, and industrial use. The capacity of our products ranges from 3 kW to 320 kW, primarily for heating, cooling, and domestic hot water. Heat pump dryers are also used for the production of tobacco, aroma wicks, medicinal herbs, tea, fruits, vegetables, and other products.

AIR TO WATER HEAT PUMP

HEATING + COOLING + DHW

CLOVERLIFE SERIES



DC Inverter EVI Technology

EVI (Enhanced Vapor Injection) is a technology that enhances the performance of heat pumps in ultra-low temperatures.



High Efficiency A+++ Energy Level

CloverLife Series DC inverter technology enables the heat pump to adjust its frequency from 30Hz to 90Hz according to real heating requirements.



Running at Low Temperature

It can maintain a more stable and efficient performance in an ambient temperature from -25°C to 43°C , providing a wide range of applications for users.



Energy-Saving up to 80%

Utilizing advanced technology to efficiently heat and cool your space, providing a sustainable and cost-effective solution for environmentally conscious homeowners.



Multi-function Selections

- Heating + Hot Water
- Cooling + Hot Water
- Heating
- Cooling
- DHW



SMART TOUCH DISPLAY



- Color Screen
- Intuitive Interface
- Touch Key Design
- Builtin Wifi Module
- APP Control

SMART CONTROL FAMILY

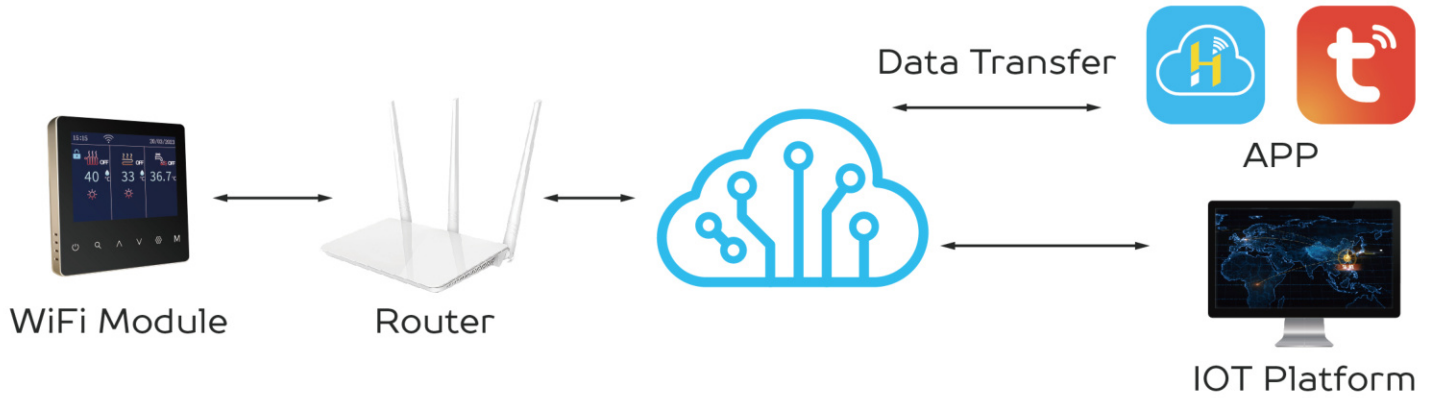

RS485

The intelligent controller with RS485 is adopted to realize the linkage control between the heat pump unit and the terminal end. Multiple heat pumps can be controlled and connected to be well monitored.

WiFi DTU

To deliver the best user experience, cloverlife series is designed with a DTU module for remote data transferring, and then you can easily monitor the running status of your heating system.

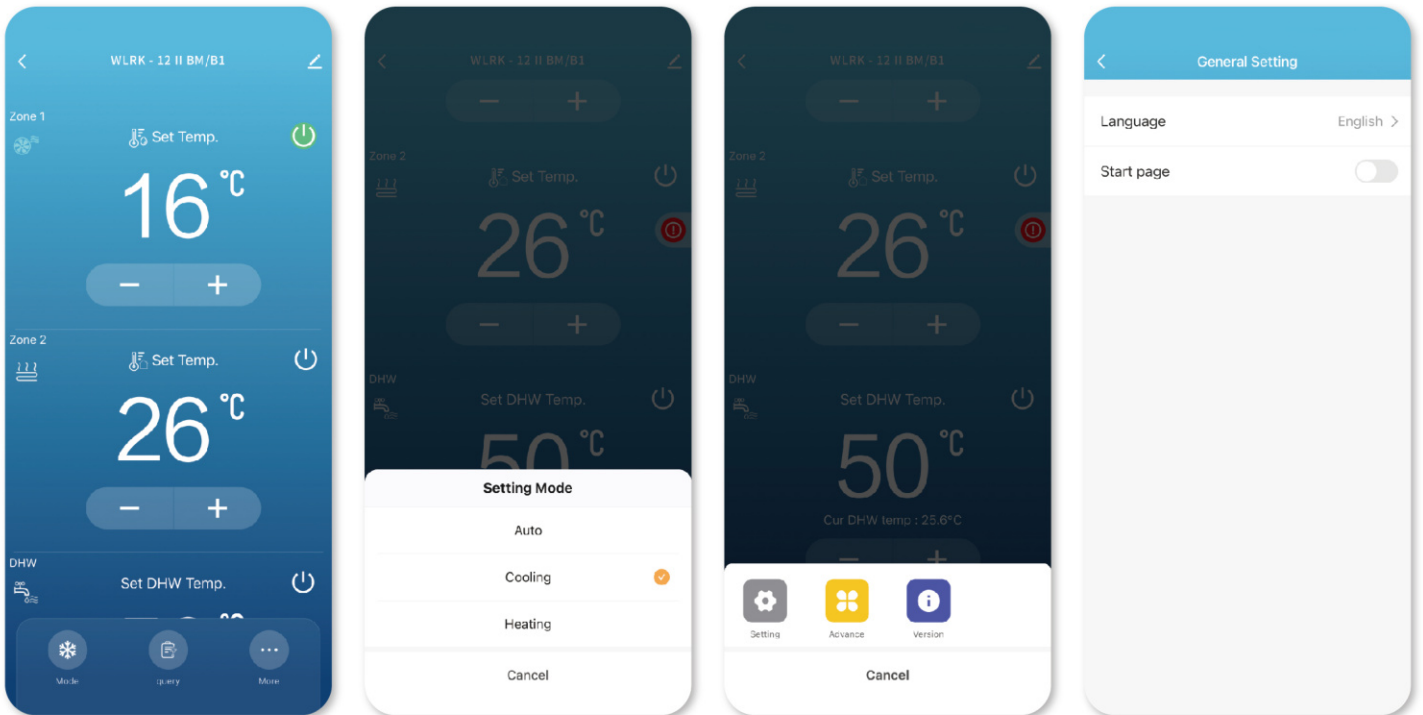

Smart APP control

Smart APP control brings a lot of convenience to users. Temperature adjustment, mode switching, and timersetting can be achieved on your smart phone. Moreover, you can know power consumption statistics and fault record at anytime and anywhere.

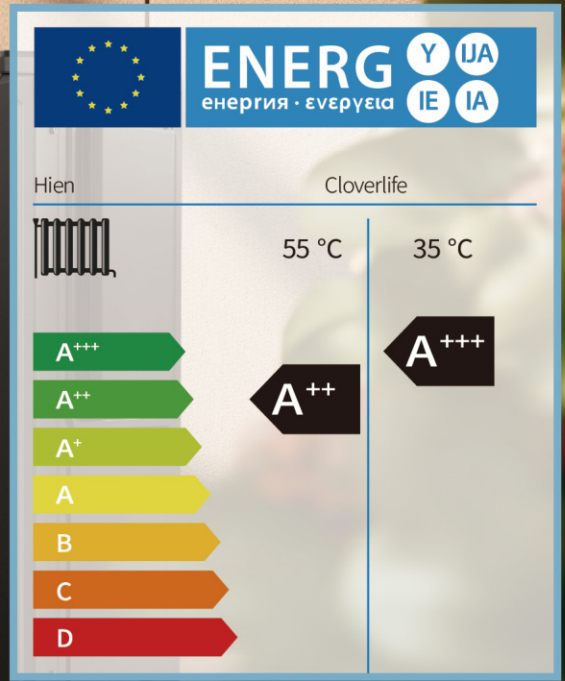

SUPER HIGH EFFICIENCY A+++

Can be operated in combination with:

1. Electric Water Heater
2. Conventional Boiler
3. Solar Hot Water Systems

Cloverlife Series delivers heat through a heating distribution system, such as radiators, underfloor heating, fan coils, or air conditioners, for reliable heating, cooling, and domestic hot water throughout the seasons. Depending on the season and air temperature, the heat pump automatically adjusts and operates optimally in the heating or cooling modes for optimal energy savings.

Suits a wide variety of applications, including space heating, domestic hot water for residential and commercial projects.

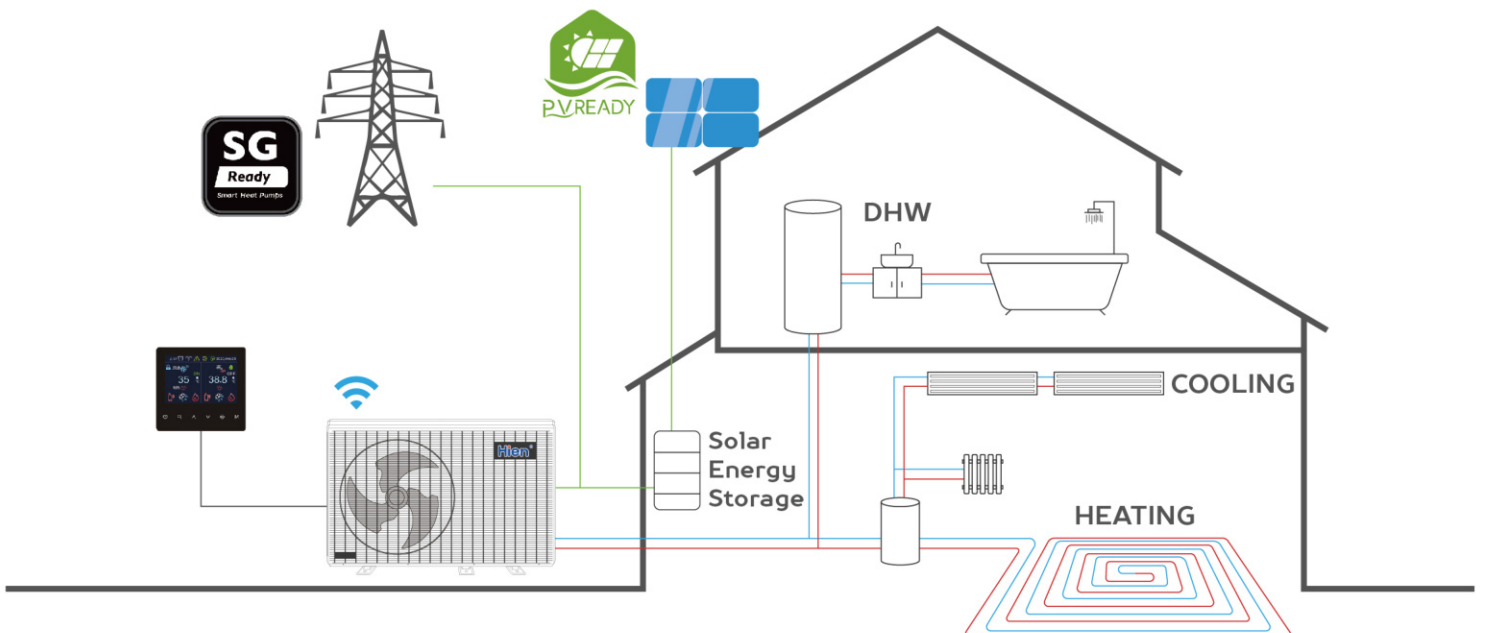

STERILIZING MODE

Thanks to its ability to reach temperatures as high as 75°C, this cutting-edge product eliminates harmful Legionella bacteria and viruses, ensuring the highest level of water safety.

Invest in your health and your family's well-being with our state-of-the-art heat pump. Experience the unparalleled convenience, energy efficiency, and superior performance that this product offers.

Don't compromise on safety and hygiene when it comes to your water supply. Choose our heat pump with its exceptional sterilizing mode, and enjoy the reassurance of pristine water quality every day.



HEATING COP CURVE

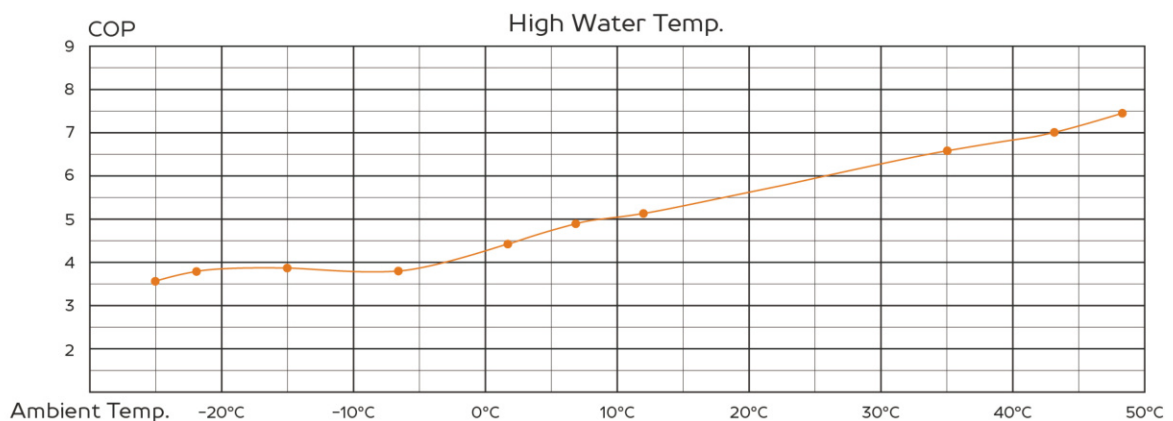
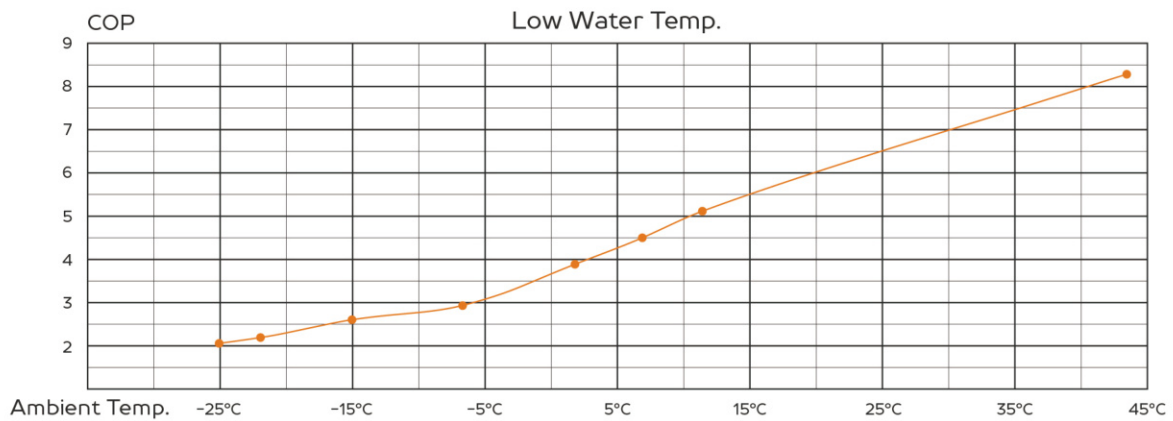

CASCADE SYSTEM DIAGRAM



- Maximum of 8 units can be controlled with one touch screen.
- Connect 1 master to 7 slaves for networking.
- Can be operated independently or in group.
- Automatically control the start and stop of the machine based on water temperature.
- Multiple heat pumps can work together to improve the efficiency and energy efficiency of the system.



SCENARIO DIAGRAM 1

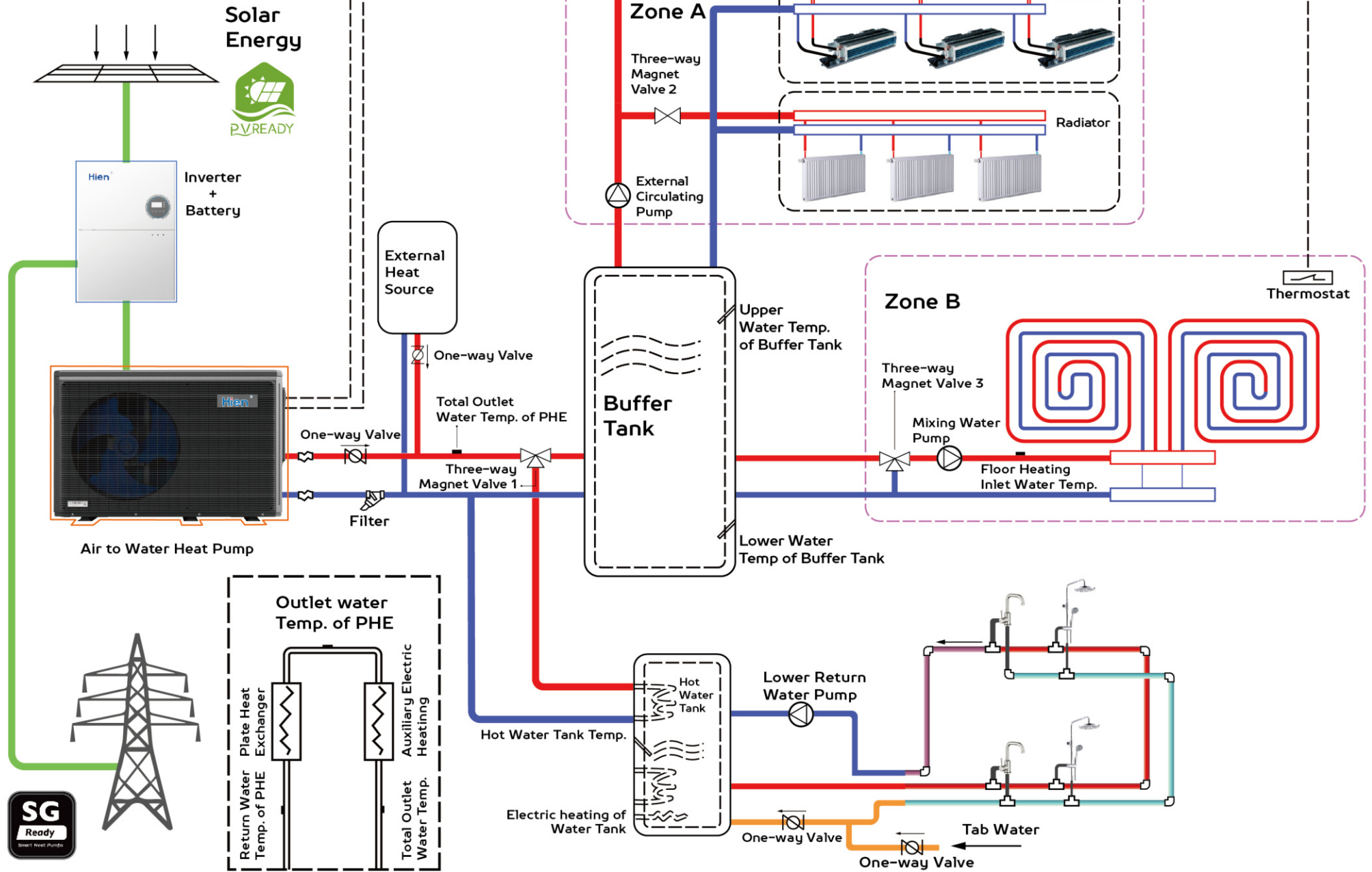

SCENARIO DIAGRAM 2

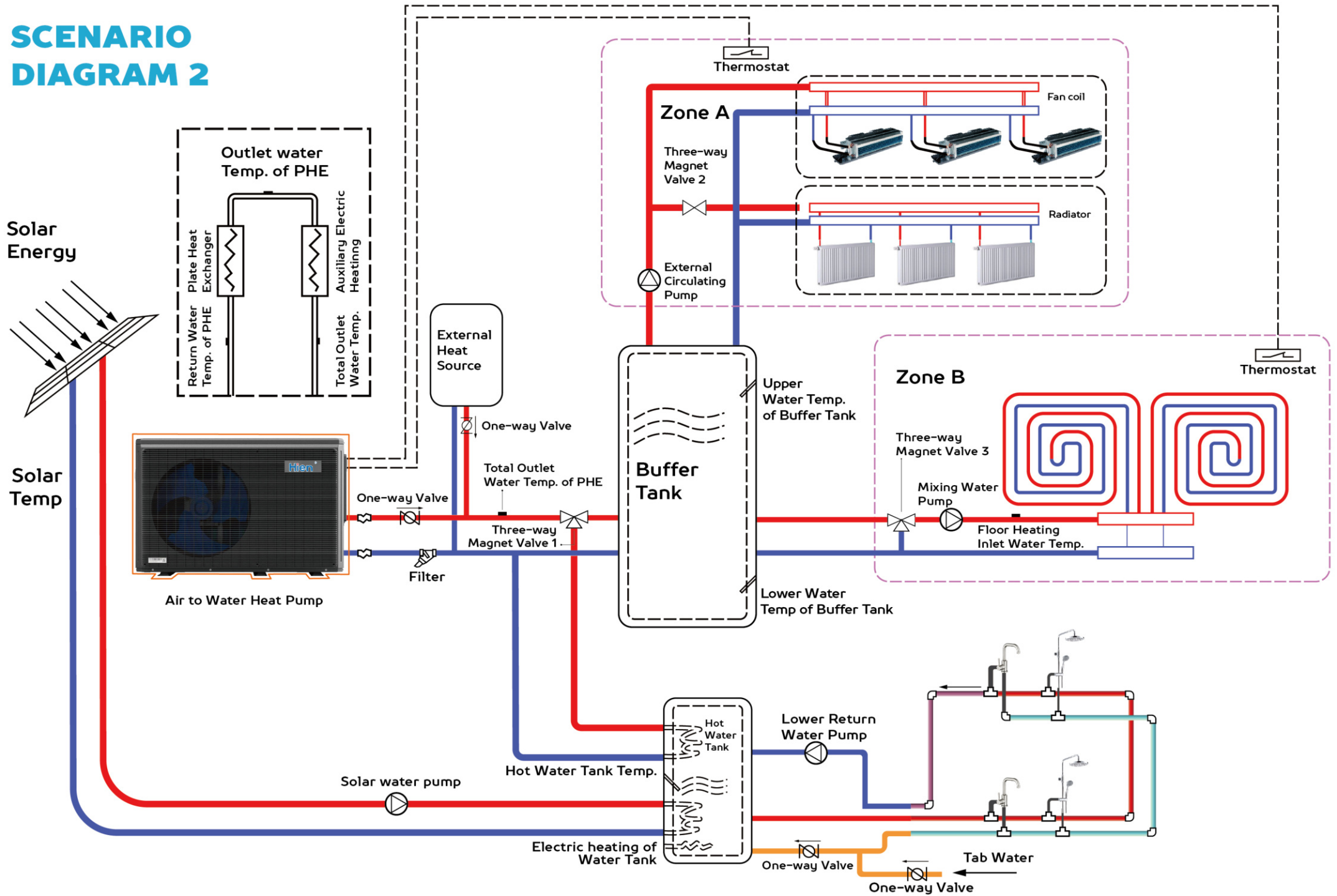

SPECIFICATIONS

SINGLE-PHASE ELECTRICITY



Dc Inverter Heat Pump			WDLRK - 8 I BM / A3	WDLRK - 10 I BM / A3	WDLRK - 12 I BM / A3	WDLRK - 14 I BM / A3	WDLRK - 16 I BM / A3
Cooling Conditions			Outdoor Air Temperature DB 35°C / WB 24°C, Indoor Water Temperature Inlet / Outlet : 23°C / 18°C.				
Rated Cooling Capacity	kW		8.60	11.20	13.20	16.70	18.80
Cooling Power Input	kW		2.31	3.40	3.80	4.70	5.26
Cooling EER	W/W		3.37	3.29	3.47	3.55	3.57
Heating Conditions			Outdoor Air Temperature DB 7°C / WB 6°C, Indoor Water Temperature Inlet / Outlet : 30°C / 35°C.				
Rated Heating Capacity	kW		7.90	10.00	11.80	13.70	16.00
Heating Power Input	kW		1.76	2.18	2.70	3.10	3.61
Heating COP	W/W		4.50	4.59	4.37	4.42	4.42
Heating Conditions			Outdoor Air Temperature DB 7°C / WB 6°C, Indoor Water Temperature Inlet / Outlet : 50°C / 55°C				
Rated Heating Capacity	kW		7.70	9.60	11.40	13.60	15.60
Heating Power Input	kW		2.60	3.28	3.80	4.50	5.20
Heating COP	W/W		2.96	2.92	3.00	3.02	3.00
Voltage	V/Hz		220V - 240V ~ / 50Hz				
Rated Water Flow	m³/h		1.36	1.72	2.06	2.43	2.75
Rated of Waterproof	/		IPX4				
Control Mode	/		Heating, Cooling, DHW, Heating + DHW, Cooling + DHW				
Refrigerant	/		R32	R32	R32	R32	R32
Compressor	Form	/	Double-rotor	Double-rotor	Double-rotor	Double-rotor	Double-rotor
	Brand	/	Panasonic	Panasonic	Panasonic	Panasonic	Panasonic
Net Size	mm		1200 * 469 * 764	1200 * 469 * 764	1200 * 469 * 764	1370 * 500 * 935	1370 * 500 * 935
Weight	kg		97	103	108	130	150
Soud Pressure Level	dB(A)		<= 55				
Fan	Form	/	Intelligent variable frequency fan motor				
Operation Ambient Temp.	°C		-25 ~ 43				
Max.Outlet Water Temp.	°C		60				
Inlet Pipe Diameter	mm		G1"	G1"	G1"	G1"	G1"
Outlet Pipe Diameter	mm		G1"	G1"	G1"	G1"	G1"
Packing Size	mm		1250 * 525 * 975	1250 * 525 * 975	1250 * 525 * 975	1450 * 550 * 1000	1450 * 550 * 1000
Wifi Function	/		✓	✓	✓	✓	✓
ErP Energy Class	/		35°C A+++ / 55°C A++				

The above parameters, if there are slight differences due to technical improvements, please refer to the relevant specifications of the actual product for accuracy.

SPECIFICATIONS

THREE-PHASE ELECTRICITY



Dc Inverter Heat Pump			WDLRK - 12 II BM/A3	WDLRK - 14 II BM/A3	WDLRK - 16 II BM/A3
Cooling Conditions			Cooling ambient temperature(DB/WB):35°C / WB 24°C , Water inlet/outlet :23°C / 18°C.		
Rated Cooling Capacity	kW		12.70	16.50	18.30
Cooling Power Input	kW		3.60	4.76	5.33
Cooling EER	W/W		3.52	3.46	3.43
Heating Conditions			Heating ambient temperature (DB/WB): 7°C/6°C, Water inlet/outlet: 30°C/35°C.		
Rated Heating Capacity	kW		11.70	14.00	16.10
Heating Power Input	kW		2.60	3.11	3.64
Heating COP	W/W		4.50	4.50	4.45
Heating Conditions			Heating ambient temperature (DB/WB): 7°C/6°C, Water inlet/outlet: 50°C/55°C.		
Rated Heating Capacity	kW		11.60	13.70	15.80
Heating Power Input	kW		3.70	4.50	5.20
Heating COP	W/W		3.13	3.04	3.03
Voltage	V/Hz		380V-420V 3N~/50Hz		
Rated Water Flow	m³/h		2.06	2.40	2.75
Rated of Waterproof	/		IPX4		
Control Mode	/		Heating, Cooling, DHW, Heating+DHW, Cooling+DHW		
Refrigerant	/		R32	R32	R32
Compressor	Form	/	Double-rotor	Double-rotor	Double-rotor
	Brand	/	Panasonic	Panasonic	Panasonic
Net Size	mm		1200 * 469* 764	1370 * 500 * 935	1370 * 500 * 935
Weight	kg		108	130	150
Soud Pressure Level	dB(A)		≤55		
Fan	Form	/	Intelligent variable frequency fan motor		
Operation Ambient Temp.	°C		-25 ~ 43		
Max.Outlet Water Temp.	°C		60		
Inlet Pipe Diameter	mm		G1"	G1"	G1"
Outlet Pipe Diameter	mm		G1"	G1"	G1"
Packing Size	mm		1250 * 525 * 975	1450 * 550 * 1000	1450 * 550 * 1000
Wifi Function	/		✓	✓	✓
ErP Energy Class	/		35°C A+++ / 55°C A++		

The above parameters, if there are slight differences due to technical improvements, please refer to the relevant specifications of the actual product for accuracy.

Hien[®]

Hien New Energy Equipment Co.,Ltd.

info@hien-ne.com

T/F : +86-0577-62121888



www.hien-ne.com

Head Office : No.9, Chuangxin Rd, Yueshang Pioneer Park, Yueqingwan Port
District, Yueqing, Zhejiang, China